

60 GHz digitally controllable and sequentially rotated fed antenna array

H. Kim[✉], Y. Lee, B. Kim, K. Baek, S. Ko, T. Yang, J. Lee and S. Nam

Sixteen-chain sequentially rotated fed antenna array on low-temperature cofired ceramic substrate is presented. A 60 GHz broadband circular polarised (CP) stacked rectangular patch antenna is implemented as an element. All the feedlines have the same length which is differentiated from conventional T-junction divider feeder. By this way, several drawbacks of conventional sequential rotated array can be overcome such as phase error occurrence, amplitude mismatch, and axial ratio bandwidth degradation. Moreover, digitally controlled by phase shifters, beamforming performance can be evaluated. The simulated and measured S_{11} shows broad bandwidth from 57 to 66 GHz. In addition, the radiation patterns show a peak gain of 17.2 dBi and a wide coverage of $\pm 63^\circ$.

Introduction: The 60 GHz communications solutions based on industrial, scientific, and medical (ISM) band are being actively developed for high-throughput. Recently, the 60 GHz communication modules have been embedded in set top boxes, laptop computers, and mobile phones. Additionally, as millimetre-wave (mmWave) frequency bands are being considered for 5G communications, mmWave antenna is expected to be equipped in mobile phones [1]. Under roll, pitch, and yaw motions of mobile phones' use scenarios, transmission and reception efficiency will be severely degraded by polarisation mismatch. Due to directional characteristics of phased array antennas, polarisation issue can be more critical in mmWave communications.

In this Letter, circular polarised (CP) antennas are applied as base station antenna array to mitigate the polarisation problem. Although receiving circularly polarised signal with linear polarised antennas will cause 3 dB degradation of the received signal strength indication (RSSI), it can avoid severe deterioration of the RSSI caused by polarisation mismatch. For the CP characteristics, numerous researchers have studied sequentially rotated fed antenna array (SRFAA) [2–5]. However, there are no papers on the integration of SRFAA with the mmWave radio frequency integrated circuit (RFIC). Using the phase shifters of the RFIC, the proposed SRFAA is digitally controllable for beamforming of the phased array antenna. The low-temperature cofired ceramic (LTCC) fabrication is adapted for embedding high-quality passives in low loss ceramic substrates and for mounting active devices.

Proposed SRFAA: It is well known that circular polarisation can be achieved with angle and phase arranged in a 0° , 90° fashion. Fig. 1a shows both the element angular orientation and feeding phase with 0° , 90° , 180° (0°), and 270° (90°). It can be summarised with a physical rotation ϕ_{pm} and a feeding phase shift ϕ_{em} as in [4]

$$\phi_{em} = (m - 1) \frac{p\pi}{M} \quad (1)$$

$$\phi_{pm} = (m - 1) \frac{p\pi}{nM}$$

where p is an integer, n is the mode number, and M is the total number of elements. To implement sequentially rotated antenna array, several papers [2, 3] achieve a feeding phase shift ϕ_{em} with different length of feedline in a T-junction power divider. However, it is valid only for the limited frequency range and phase errors occur as the guided wavelength varies with frequency. For example, 90° of phase can be achieved with 0.519 mm length of feedline ($\epsilon = 5.8$) at 60 GHz, whereas the phase becomes 99° at 66 GHz. In consequence, it can reduce axial ratio bandwidth which can be quantified by a cross-polarised improvement factor F_x and a fractional deviation δ as in [4]

$$F_x = \frac{2M}{p\pi\delta} \sin \frac{p\pi}{M} \quad (2)$$

Due to different length of the transmission line, there are amplitude mismatch and phase errors with frequency deviation. However, by applying the equal length of feed line for the proposed topology, these drawbacks can be overcome and feeding loss can be minimised as the shortest path is selected. Additionally, beamforming is possible as phase shifters in an RFIC are used for the feeding phase shift.

Total phase can be modified to $\phi_{em} + \phi_{bm}$, where ϕ_{bm} is the phase for array beamforming.

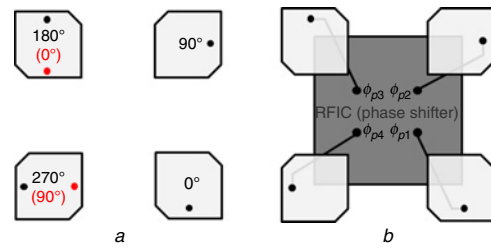

Fig. 1 Configuration of sequentially rotated antenna array
a Angular orientation and feeding phase of four-chain array
b Antenna array integrated with RFIC

Antenna design: Fig. 2a illustrates the layer structure of the LTCC module. The LTCC package consists of nine stacked layers, each having a relative permittivity of 5.85 and a loss tangent of 0.0038. Antenna layers have a fired thickness of $100 \mu\text{m}$ and strip feed line layers have thickness of $75 \mu\text{m}$. The antenna element and its design parameters are shown in Fig. 2b. A stacked rectangular patch antenna is devised for circular polarisation and wide bandwidth of reflection coefficient. Two separate patches are implemented on the first layer and the third layer. A probe feed is realised by connecting a signal via hole at a certain distance L_F from the edge of the bottom patch. A parametric study to satisfy 60 GHz ISM band is performed using Ansys HFSS. As an axial ratio of an element has influence on the peak gain of the antenna array [5], design parameters are optimised to maximise the 3 dB bandwidth of element axial ratio. A cavity consists of ground via holes implemented to reduce surface wave which causes ripples in the radiation patterns. Additionally, it can reduce mutual coupling between antenna elements. By constituting the fence of ground via holes with diamond shape, interleaved 16-chain transmitter (Tx) and 16-chain receiver (Rx) can be fabricated in a compact size as shown in Fig. 3b. The finalised design parameters of the stacked rectangular patch antenna are $W_{TP} = 0.58 \text{ mm}$, $W_{TPC} = 0.18 \text{ mm}$, $W_{BP} = 0.68 \text{ mm}$, $W_{BPC} = 0.18 \text{ mm}$, $L_{TP} = 0.7 \text{ mm}$, $L_{TPC} = 0.25 \text{ mm}$, $L_{BP} = 0.8 \text{ mm}$, $L_{BPC} = 0.25 \text{ mm}$, $G_{\text{via}} = 0.3 \text{ mm}$, $L_{\text{CRL}} = 2.1 \text{ mm}$, and $L_F = 0.6 \text{ mm}$.

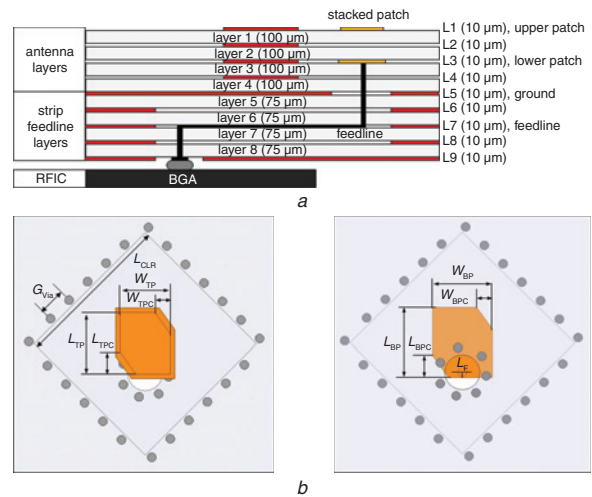

Fig. 2 Geometry and dimensions of proposed patch antenna element
a Layer configuration of antenna module
b Top view of antenna element

Fabrication and measurements: The detailed configuration of the proposed SRFAAs is shown in Fig. 3a. The overall dimension of the presented module is $14.5 \times 14.5 \times 8 \text{ mm}^3$. Array spacing of 3 mm ($\sim 0.6\lambda$) is selected for interleaved T/Rx design. The 32-chain interleaved array of proposed topology is designed and fabricated as shown in Fig. 3b. The simulated and measured S_{11} of port 2 are presented in Fig. 4a. The return loss of elements shows wideband from 57 to 66 GHz, which satisfies 60 GHz ISM band. The reflection coefficient of the array antenna is slightly shifted due to the shrinkage

during sintering process. The simulated axial ratio of the proposed 16-chain sequential rotated array shows wideband performance.

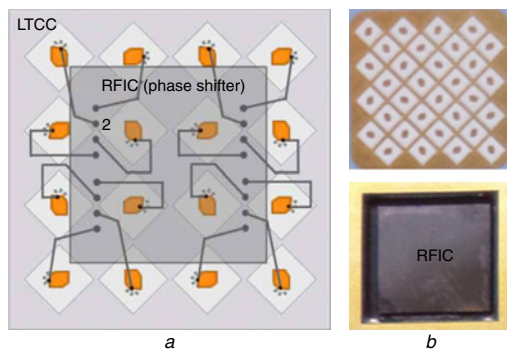

Fig. 3 Proposed SRFAA

a Configuration of 16-chain array
b Fabricated 32-chain Tx/Rx interleaved array

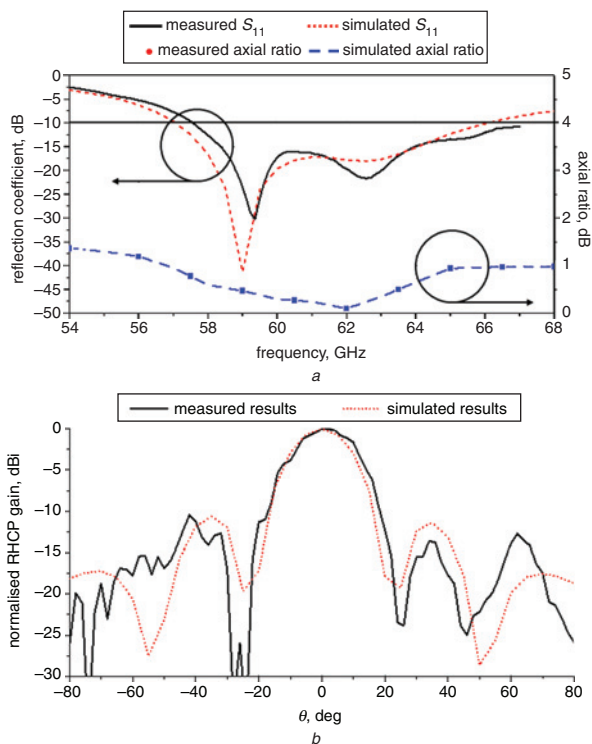

Fig. 4 Comparison of measured and simulated results

a Reflection coefficient of single element
b Normalised radiation pattern of 16-chain array

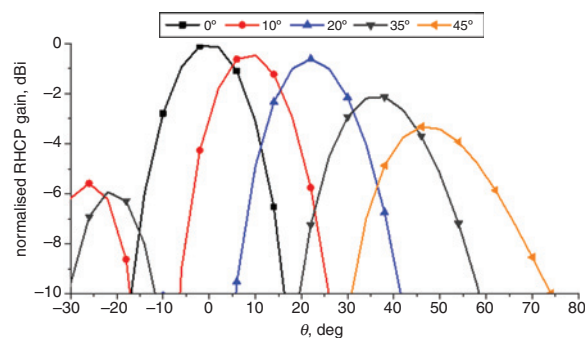

Fig. 5 Beamformed radiation patterns with normalised RHCP gain

Fig. 4b presents simulated and measured radiation patterns of the proposed antenna array which shows well-matched results. This shows a peak gain of 17.2 dBi at 62.64 GHz and a half power beam width of about 25°. The average radiation efficiency of the designed antenna element is calculated to be ~89% between 57 and 66 GHz.

Fig. 5 illustrates simulated right hand CP (RHCP) gain and the tilted beam performance with wide coverage of $\pm 63^\circ$. By adding the beamforming phase to the phase for sequential rotation, beamforming is possible maintaining good axial ratio. The RSSI of total transmitting array with an RFIC is measured and compared. While the 16-chain linear polarised antenna array shows the RSSI of 42.5 dB with a vertical polarised receiver, the proposed antenna array shows the RSSI of 39.4 and 38.7 dB with vertical and horizontal polarised receiver, respectively.

Conclusion: A SRFAA topology is proposed and investigated. The antenna in package has been simulated with full structure. The structure is verified with 32-chain T/Rx array using a broadband CP stacked rectangular patch antenna as an element. The proposed antenna exhibits higher performance compared with a conventional sequential rotated array.

Acknowledgments: This work was supported by ‘The Cross-Ministry Giga KOREA Project’ Grant from the Ministry of Science, ICT and Future Planning, Korea.

© The Institution of Engineering and Technology 2017

Submitted: 26 November 2016 E-first: 2 June 2017

doi: 10.1049/el.2016.4300

One or more of the Figures in this Letter are available in colour online.

H. Kim, Y. Lee, B. Kim, K. Baek, S. Ko, T. Yang and J. Lee (*Samsung Electronics, Suwon, Republic of Korea*)

✉ E-mail: hyunjin7.kim@samsung.com

S. Nam (*School of Electrical Engineering, Seoul National University, Seoul, Republic of Korea*)

H. Kim: Also with School of Electrical Engineering, Seoul National University, Seoul, Republic of Korea

References

- Hong, W., Baek, K., Lee, Y., and Kim, Y.L.: ‘Study and prototyping of practically large-scale mmWave antenna systems for 5G cellular devices’, *IEEE Commun. Mag.*, 2014, **52**, (9), pp. 63–69, doi: 10.1109/MCOM.2014.6894454
- Li, Y., Chen, Z., Qing, X., Zhang, Z., Xu, J., and Feng, Z.: ‘Axial ratio bandwidth enhancement of 60-GHz substrate integrated waveguide-fed circularly polarized LTCC antenna array’, *IEEE Trans. Antennas Propag.*, 2012, **60**, (10), pp. 4619–4626, doi: 10.1109/TAP.2012.2207343
- Zhang, W., Zhang, Y.P., Sun, M., Luxey, C., Titz, D., and Ferrero, F.: ‘A 60-GHz circularly-polarized array antenna-in-package in LTCC technology’, *IEEE Trans. Antennas Propag.*, 2013, **61**, (12), pp. 6228–6232, doi: 10.1109/TAP.2013.2279992
- Hall, P.S., Daele, J.S., and James, J.R.: ‘Design principles of sequentially fed, wide bandwidth, circularly polarised microstrip antennas’, *IEE Proc. Antennas Propag.*, 1989, **136**, (5), pp. 381–389
- Hall, P.S.: ‘Application of sequential feeding to wide bandwidth, circularly polarised microstrip patch arrays’, *IEE Proc. Antennas Propag.*, 1989, **136**, (5), pp. 390–398